

NEXT-GEN INNOVATIONS IN CRUSHING & SCREENING SOLUTIONS

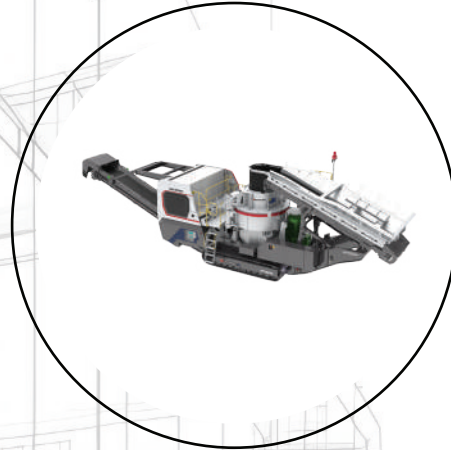

OUR STATE OF THE ART INFRASTRUCTURE

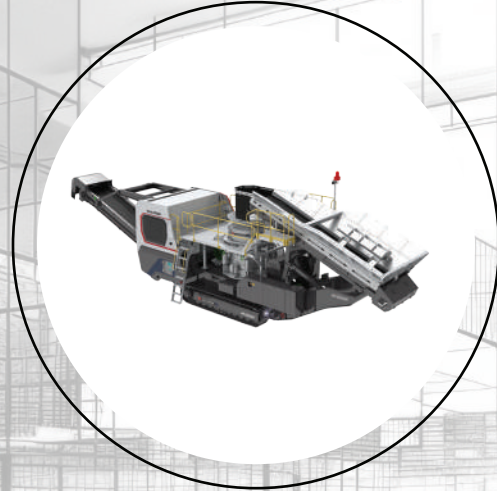
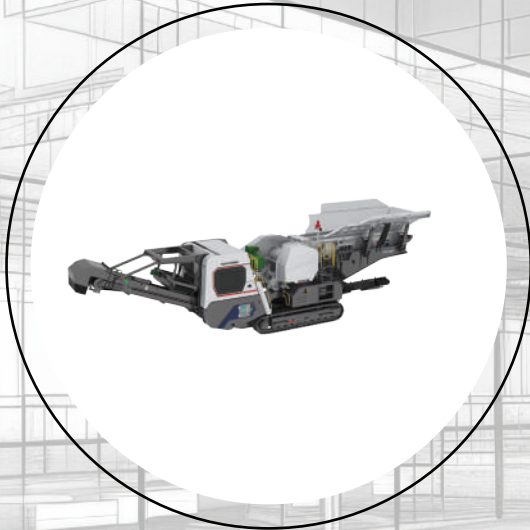

hailstonein.com

ABOUT US

The finest choice for sustainable value addition of natural resources in the world, Hailstone innovations Pvt Ltd., is one of the leading Crushing & screening equipment manufacturer from India. Hailstone specializes in engineering, designing, fabricating, and manufacturing capital equipment, as well as completing turnkey projects for the mining and aggregates industries. We provide safe, secure, low operating cost and highly efficient machines for our patrons that perfectly suit their requisites.

The Hailstone infrastructure comprises a stellar assemblage of state of the art machinery, tools, and instruments / machines to craft world-class construction and mining equipment for the global customers. As a fast-growing professionally managed organization in the sustainable mineral processing industry, we hold a great responsibility towards our clients, employees, partners, environment and the society.

All along this wonderful journey, shouldering this responsibility in the best possible way have been our strategy to operate in this world. Through innovation, we deliver ingenious solutions for the industry.

The client can feel quality and trust in our equipment which helps and motivates us to better serve the world. With an agile approach and far-reaching global presence, Over the years, we have shaped an effective organizational structure that grants the firm operational excellence on par with some of the best-run enterprises in the world

By embracing latest innovative digital services and goods, we have committed ourselves to deliver the best to our clients. At Hailstone, our strategy is always to innovate efficiently to ensure our customers' success and prosperity.

hailstonein.com

Scan to visit website



TRACK MOUNTED JAW

Hail Track-HTJ Series

Hailstone track mounted jaw crusher is used as a primary crusher in a multistage crushing process or as a stand-alone unit. It is ideal for medium-sized aggregates production, as well in as recycling of demolition waste such as concrete & asphalt waste.

CONVEYOR

- The 1000 belt-width discharge conveyor is driven by motorised pulley.
- It is hydraulically foldable

MAGNETIC SEPARATOR

- 750 belt width magnetic conveyor
- Electric motor driven belt conveyor
- Permanent magnet & height adjustable

HYBRID POWER MODE

- Diesel Electric

HIGH MAST LIGHT

- Lighting over a large area
- High performance

JAW CRUSHER

- Strong bolting for better strength
- Lesser Maintenance & higher mechanical efficiency
- Hydraulic CSS adjustment

FEED HOPPER

- Hydraulically foldable
- Wear resistant Extension for more capacity

GRIZZLY FEEDER

- Efficient material flow with high stroke vibrating unit
- Long life & easy maintenance
- Wear resistant grizzly liners

FINE CONVEYOR

- 180 degree rotatable conveyor
- The 500 belt width fines conveyor is driven by motorised pulley

EXTENSIVE PLATFORMS FOR MAINTENANCE

- Optimized weight & more lifetime
- Mobility on uneven terrain

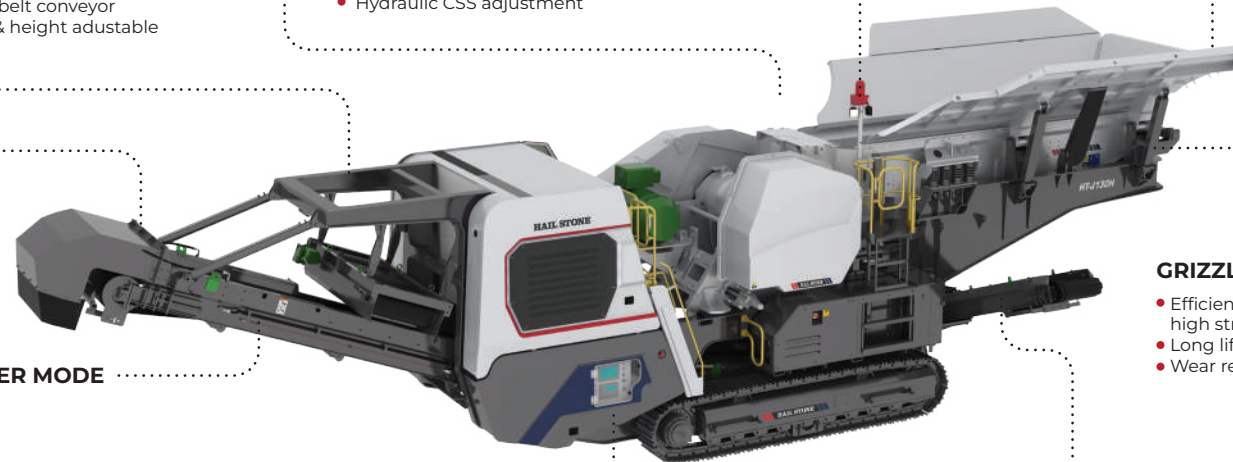

EASY
TO MAINTAIN



ENVIRONMENT
FRIENDLY



ENERGY
EFFICIENT



DURABLE &
RIGID DESIGN

Model	HT J130-H
Crusher	
Model	JC130
Opening Size, mm (in)	1067 x 813 (42 x 32)
CSS Range, mm	70 - 200
*Capacity, mtph	127 - 520
System	
Hopper Capacity, m ³	6/10*
Grizzly Feeder	GFEM4211
Feeder Size, mm (in)	1100 x 4200 (43.3 x 165.3)
Discharge Conveyor	
Belt Width, mm (in)	1000 (39.4)
Discharge Height, mm (in)	2800 (110.2) / 3800 (149.6)
Stock Pile Capacity, m ³ @ 40°	33 / 82
Drive type / Power, kW	Motorized pulley / 11
Fines Conveyor	
Belt Width, mm (in)	500 (19.7)
Discharge Height, mm (in)	2100 (82.7)
Stock Pile Capacity, m ³ @ 40°	14
Drive type / Power, kW	Motorized pulley / 3
Under Carriage	
Shoe Width, mm (in)	400 (19.7)
Gradability	15°
Speed, km/h	0.6 - 1.2
Hydraulic Tank Capacity, litre	130
Hydraulic Motor Power, kW (hp)	55 (75)
Power Unit	
Power, kW	248
Generator power, kVA	320
Engine / Alternator	CAT – C7.1 / VOLVO D8 Engine with Stamford / LS Alternator
Diesel Tank Capacity, litre	600
Dimensions	
Transportation (L x W x H), mm (in)	14900 x 2850 x 3550 (586.6 x 112.2 x 139.8)
Working (L x W x H), mm (in)	15200 x 2850 x 4200 (598.4 x 112.2 x 165.4)
Weight, kg (lbs)	50000 (110500)

*Option

TRACK MOUNTED JAW

Hail Track-HTJ Series

The HT 45 features a 711 x 407 mm single toggle Jaw Crusher. It is compact in size providing versatility, maneuverability and ease of transport. It is small enough to fit inside a container but strong to withstand toughest of applications.

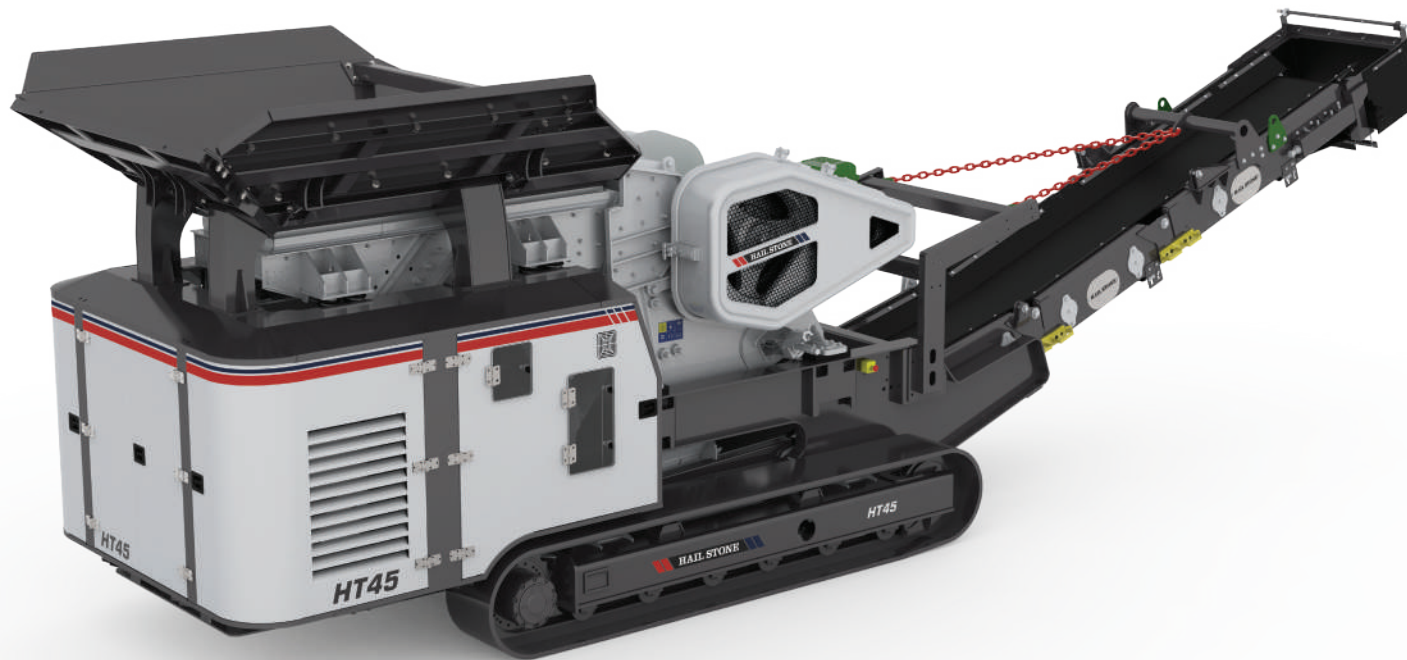

**EASY TO
MAINTAIN**



**ENERGY
EFFICIENT**



**ENVIRONMENT
FRIENDLY**



**PLUG IN
ELECTRICAL**

Model	HT J45
Crusher	
Model	JC45
Opening Size, mm (in)	711 x 407 (28 x 16)
CSS Range, mm	20 - 100
*Capacity, mtp/h	20 - 50
System	
Hopper Capacity, m ³	2
Grizzly Feeder	GFEM2107
Feeder Size, mm (in)	2100 x 700 (82.7 x 27.5)
Discharge Conveyor	
Belt Width, mm (in)	800 (31.5)
Discharge Height, mm (in)	2012 (79.2)
Stock Pile Capacity, m ³ @ 40°	12
Drive type / Power, kW	Motorized pulley / 5.5
Fines Conveyor	
Belt Width, mm (in)	-
Discharge Height, mm (in)	-
Stock Pile Capacity, m ³ @ 40°	-
Drive type / Power, kW	-
Under Carriage	
Shoe Width, mm (in)	400 (19.7)
Gradability	15°
Speed, km/h	0.6 - 1.2
Hydraulic Tank Capacity, litre	150
Hydraulic Motor Power, kW (hp)	22 (30)
Power Unit	
Power, kW	59
Generator power, kVA	80
Engine / Alternator	Volvo Eicher with Stamford alternator
Diesel Tank Capacity, litre	150
Dimensions	
Transportation (L x W x H), mm (in)	6382 x 2250 x 2750 (251.2 x 88.6 x 108.3)
Working (L x W x H), mm (in)	9366 x 2250 x 2800 (368.7 x 88.6 x 110.2)
Weight, kg (lbs)	15000 (33150)

*Option

TRACK MOUNTED CONE

Hail Track-HTC Series

Hailstone track mounted cone crusher shall be used as a secondary crusher in a multistage crushing process or as a stand-alone unit. It is ideal for fine and coarse aggregates production, as well as in recycling of concrete waste and asphalt waste.

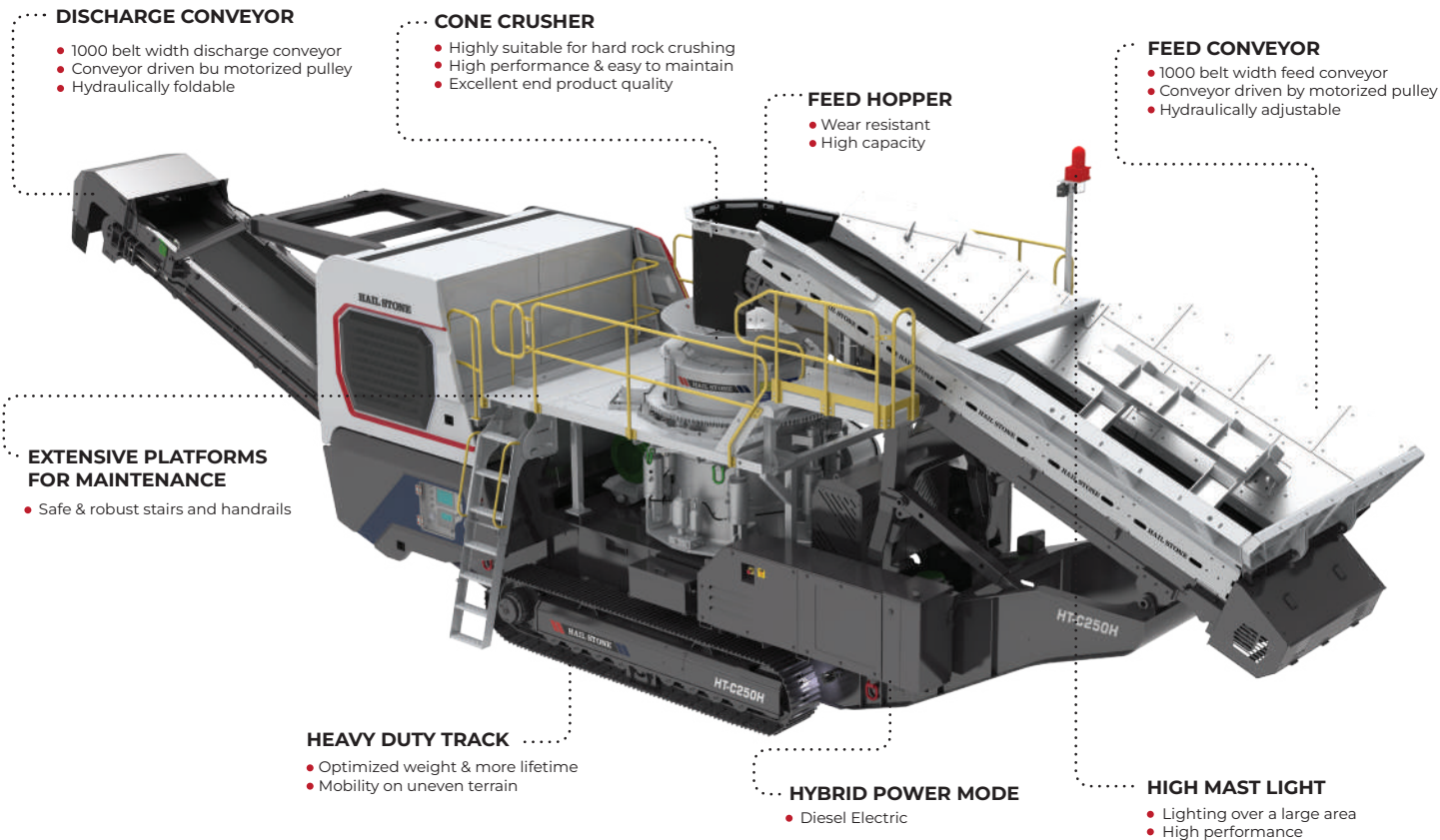

SUITED FOR RUGGED APPLICATION



ENVIRONMENT FRIENDLY



PLUG IN ELECTRICAL



READY TO RUN

Technical Specification

Model	HT C250-H
Crusher	
Model	EC2500
Opening Size, mm (in)	190 (7.5)
CSS Range, mm	19 - 38
*Capacity, mtph	150 - 260
System	
Hopper Capacity (Extended), m ³	6 / 10*
Feed belt width, mm (in)	1000 (39.4)
Feed height, mm (in)	3150 (124)
Main Conveyor	
Belt Width, mm (in)	1000 (39.4)
Discharge Height, mm (in)	2800 (110.2) / 3800 (149.6)
Stock Pile Capacity, m ³	75
Under Carriage	
Shoe Width, mm (in)	400 (19.7)
Gradability	15°
Hydraulic Tank Capacity, litre	130
Power Unit	
Power, kW	248
Generator power, kVA	400
Engine / Alternator	Volvo/CAT with Stamford / LS Alternator
Diesel Tank Capacity, litre	600
Dimensions	
Transportation (L x W x H), mm (in)	16500 x 2850 x 3550 (649.6 x 112.2 x 139.8)
Working (L x W x H), mm (in)	15500 x 2850 x 3550 (610.2 x 112.2 x 139.8)
Weight, kg (lbs)	45000 (99450)

*Option

TRACK MOUNTED VSI

Hail Track - HT Series

Hailstone track mounted Vertical Shaft Impactor is used as a tertiary crusher in a multistage crushing process or as a stand alone unit. It is ideal for producing fine aggregates.

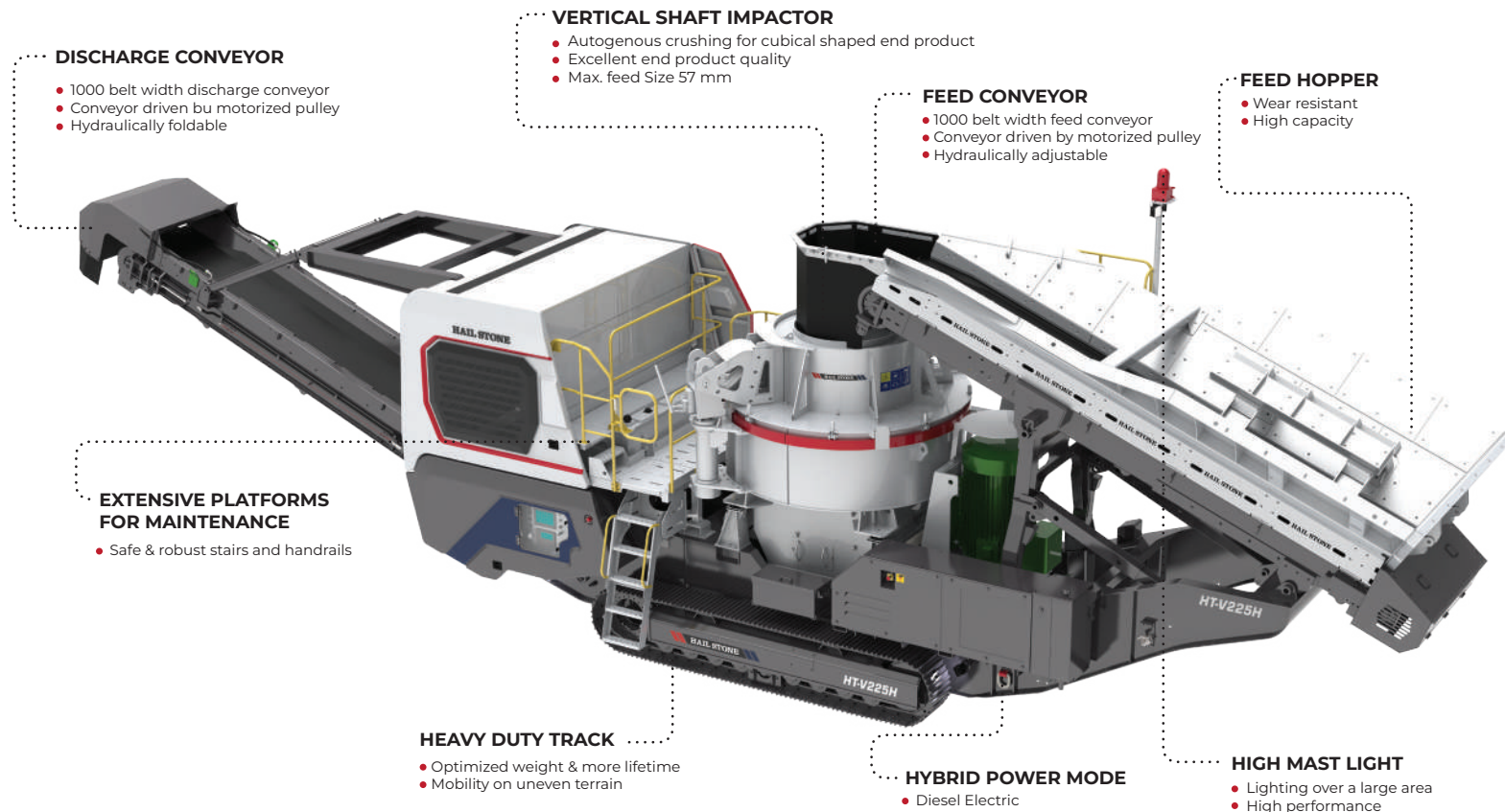

SUITED FOR RUGGED APPLICATION



AUTOGENOUS CRUSHING FOR CUBICAL SHAPED END PRODUCT



HYBRID W/PLUG-IN ELECTRICAL



EXCELLENT END PRODUCT QUALITY

Technical Specification

Model	HT V225-H
Crusher	
Model	VSIEP8X225
Feed Size, mm (in)	45 (1.8)
*Capacity, mtpH	150 - 350
System	
opper Capacity (Extended), m3	6 / 10*
Feed belt width, mm (in)	1000 (39.4)
Feed height, mm (in)	3150 (124)
Main Conveyor	
Belt Width, mm (in)	1000 (39.4)
Discharge Height, mm (in)	2800 (110.2) / 3800 (149.6)
Stock Pile Capacity, m3	75
Under Carriage	
Shoe Width, mm (in)	400 (19.7)
Gradability	15°
Hydraulic Tank Capacity, litre	130
Power Unit	
Power, kW	364
Generator power, kVA	500
Engine / Alternator	SCANIA DC13/CAT C13 with Stamford / LS Alternator
Diesel Tank Capacity, litre	600
Dimensions	
Transportation (L x W x H), mm (in)	16500 x 2850 x 3550 (649.6 x 112.2 x 139.8)
Working (L x W x H), mm (in)	15500 x 2850 x 3550 (610.2 x 112.2 x 139.8)
Weight, kg (lbs)	40000 (88400)

*Option

TRACK MOUNTED SCREEN

Hail Track-HTS Series

Hailstone track mounted screen unit is used as a secondary or tertiary screen station in a multistage crushing process or as a stand-alone unit. Hailstone track mounted screening station is equipped with a vibrating screen specially designed for screening in mobile applications.

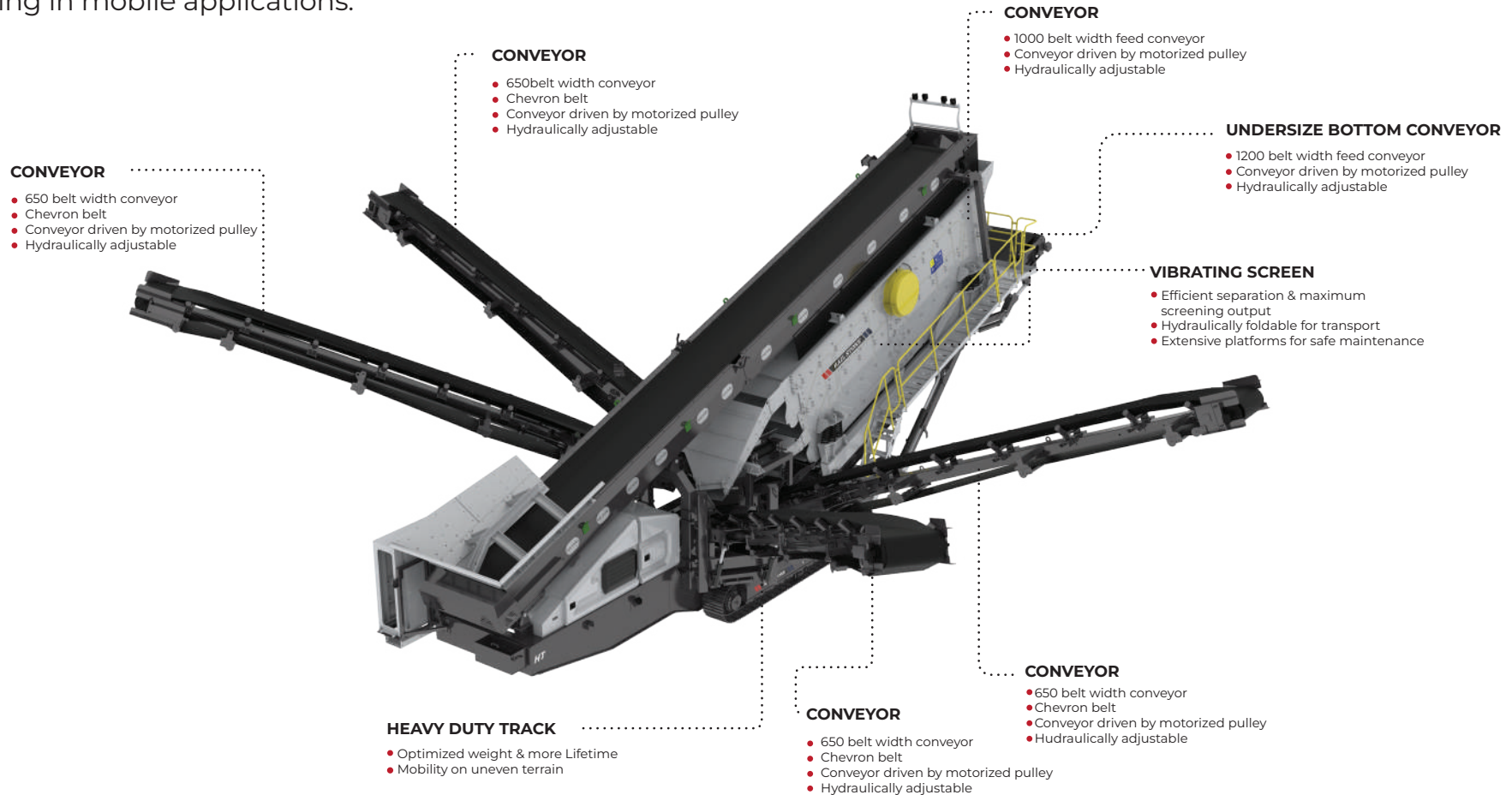

EASY
TO MAINTAIN



ENVIRONMENT
FRIENDLY



COMPACT
DESIGN



LOW POWER
CONSUMPTION

Model	HT S309G-H	HT S411-H
Screen		
Model	VS1560-3D	DS1860-4D
Deck Size, mm (in)	6000 X 1500	6000 X 1850
No. of Decks	3	4
Hopper		
Hopper Capacity, m ³	7.5	2.1
Feeding Height, mm (in)	4100 (161.5)	2520 (99.2)
Grid	Tipping grid / Vibrating grid	NA
Feeding Conveyor		
Belt Width, mm (in)	1000 (39.4)	1000 (39.4)
Feeding Height, mm (in)	NA	2520 (99.2)
Oversize Conveyor Product Conveyor - 1 2 3		
Belt Width, mm (in)	500 (19.7) 800 (31.5) 800 (31.5)	650 (25.6) 650 (25.6) 650 (25.6) 650 (25.6)
Discharge Height, mm (in)	4800 (188.9)	4800 (188.9)
Undersize Bottom Conveyor		
Belt Width, mm (in)	1200 (47.3)	1200 (47.3)
Discharge Height, mm (in) @ 18°	3025 (119.1)	3200 (125.9)
Stock Pile Capacity, m ³	41	49
Under Carriage		
Shoe Width, mm (in)	400 (15.8)	400 (15.8)
Gradability, degree	15°	15°
Power Unit		
Power, kW	116	116
Generator power, kVA	125	125
Engine / Alternator	CAT / VOLVO EICHER with Stamford / LS Alternator	CAT / VOLVO EICHER with Stamford / LS Alternator
Diesel Tank Capacity, litre	350	350
Dimensions		
Transportation (L x W x H), mm (in)	18500 x 3050 x 3550 (728.3 x 120.1 x 139.8)	16250 x 3200 x 4200 (639.8 x 125 x 165.3)
Working (L x W x H), mm (in)	19000 x 18000 x 5500 (748 x 708.7 x 216.5)	17500 x 17750 x 7000 (688 x 698.8 x 275.6)
Weight, kg (lbs)	40000 (88400)	45000 (99450)

*Option

WHEEL MOUNTED PLANT

SMART-JHF Series

Hailstone wheel mounted 2 stage plant is used as a primary and second stage crusher in a multistage crushing process. It is ideal for medium-sized aggregates production. Hailstone wheel mounted crusher plant is equipped with Hailstone jaw crusher unit and cone crusher unit especially designed for crushing hard rock types such as granite, basalt and gneiss as well Demolition waste.

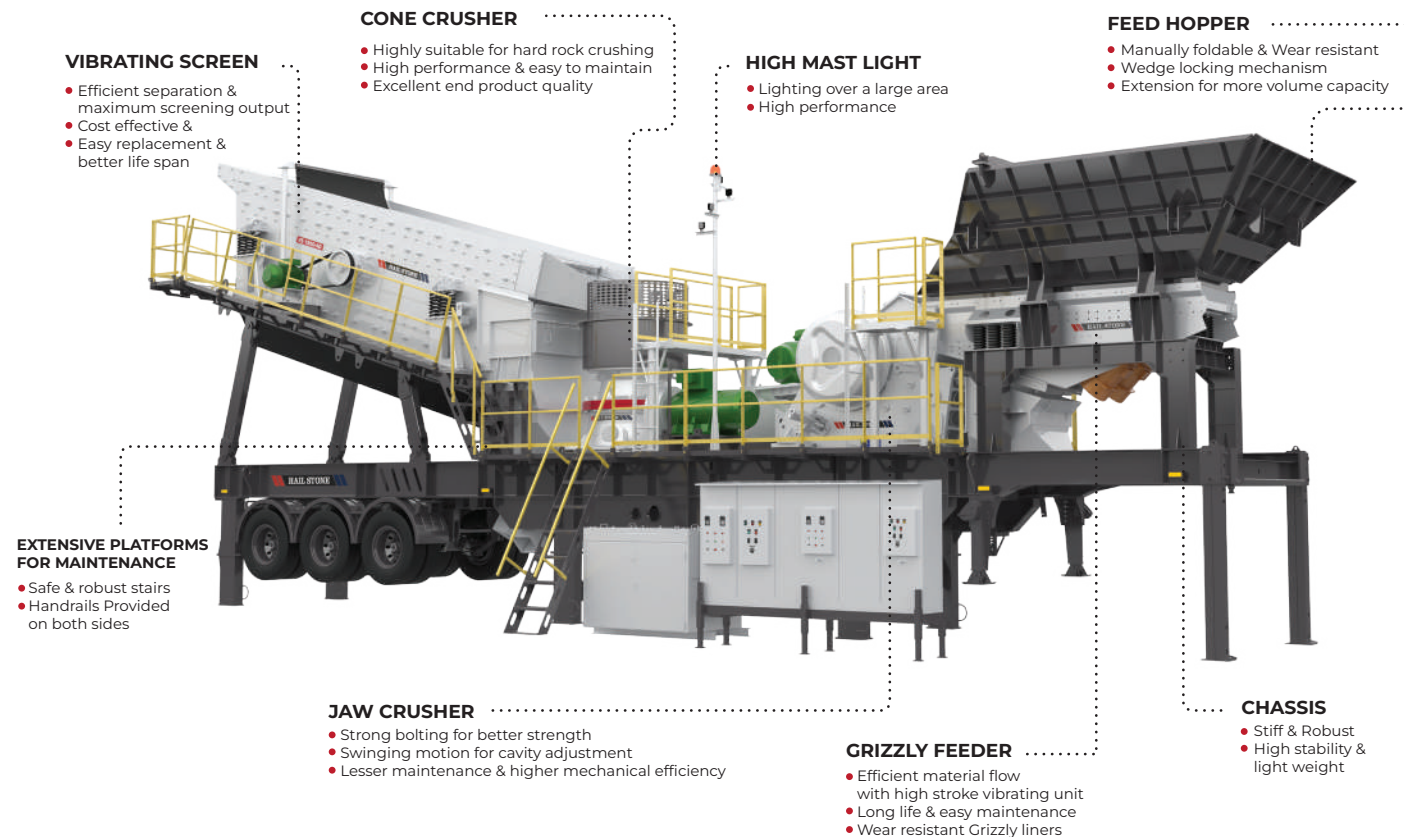

**QUICK
INSTALLATION**



**ERGONOMIC
DESIGN**



**FASTER RETURN
ON INVESTMENT**

Technical Specification

Model	SMART J-HF150	SMART J-HF230	SMART J-HF270
Feeder			
Model	GFEM3209	GFEM3211	GFEM3211
Grizzly Length, mm	2 x 750	2 x 750	2 x 750
Grizzly Gap, mm	35 - 90	35 - 90	35 - 90
Power, kW (hp)	7.6 (10.1)	8.6 (11.5)	8.6 (11.5)
Hopper Capacity, m ³	5	6.6	6.6
Jaw Crusher			
Model	JC100	JC130	JC130
Opening size, mm x mm (inch x inch)	914 x 660 (36 x 26)	1067 x 813 (42 x 32)	1067 x 813 (42 x 32)
C.S.S Range, mm	60 - 175	70 - 200	70 - 200
Capacity, tph	105 - 390	127 - 520	127 - 520
Power, kW (hp)	75 (100)	110 (150)	110 (150)
Cone Crusher			
Model	HF150	HF220	HF270
Feed Opening size, mm	150	172	220
C.S.S Range, mm	20 - 30	20 - 40	20 - 30
Capacity, mtph	84 - 160	160 - 260	70 - 260
Power, kW (hp)	110 (150)	160 (220)	220 (300)
Screen			
Model	VS1850-4D	VS1850-4D	DS1860-4D
Width, mm	1850	1850	1850
Length	5000	5000	6000
No of Desk, nos	4	4	4
Power, kW (hp)	15 (20)	15 (20)	15 (20)
Dimensions			
Transportation (L x W x H), mm (in)	16561 x 3054 x 4700 (652 x 120 x 185)	17320 x 3295 x 4700 (682 x 130 x 185)	17970 x 3029 x 4861 (707 x 119 x 191)
Working (L x W x H), mm (in)	16156 x 5159 x 6651 (636 x 203 x 262)	16714 x 5154 x 6651 (658 x 203 x 262)	18671 x 5288 x 8091 (735 x 208 x 318)
Weight, kg (lbs)	60000 (132277)	75000 (165347)	82000 (180779)

WHEEL MOUNTED PLANT

SMART-EP Series

Hailstone wheel mounted VSI plant is used as a tertiary stage crusher in a multistage crushing process. It is ideal for fine aggregates production. Hailstone wheel mounted crusher plant is equipped with crushing unit especially designed for crushing hard rock types such as granite, basalt and gneiss.

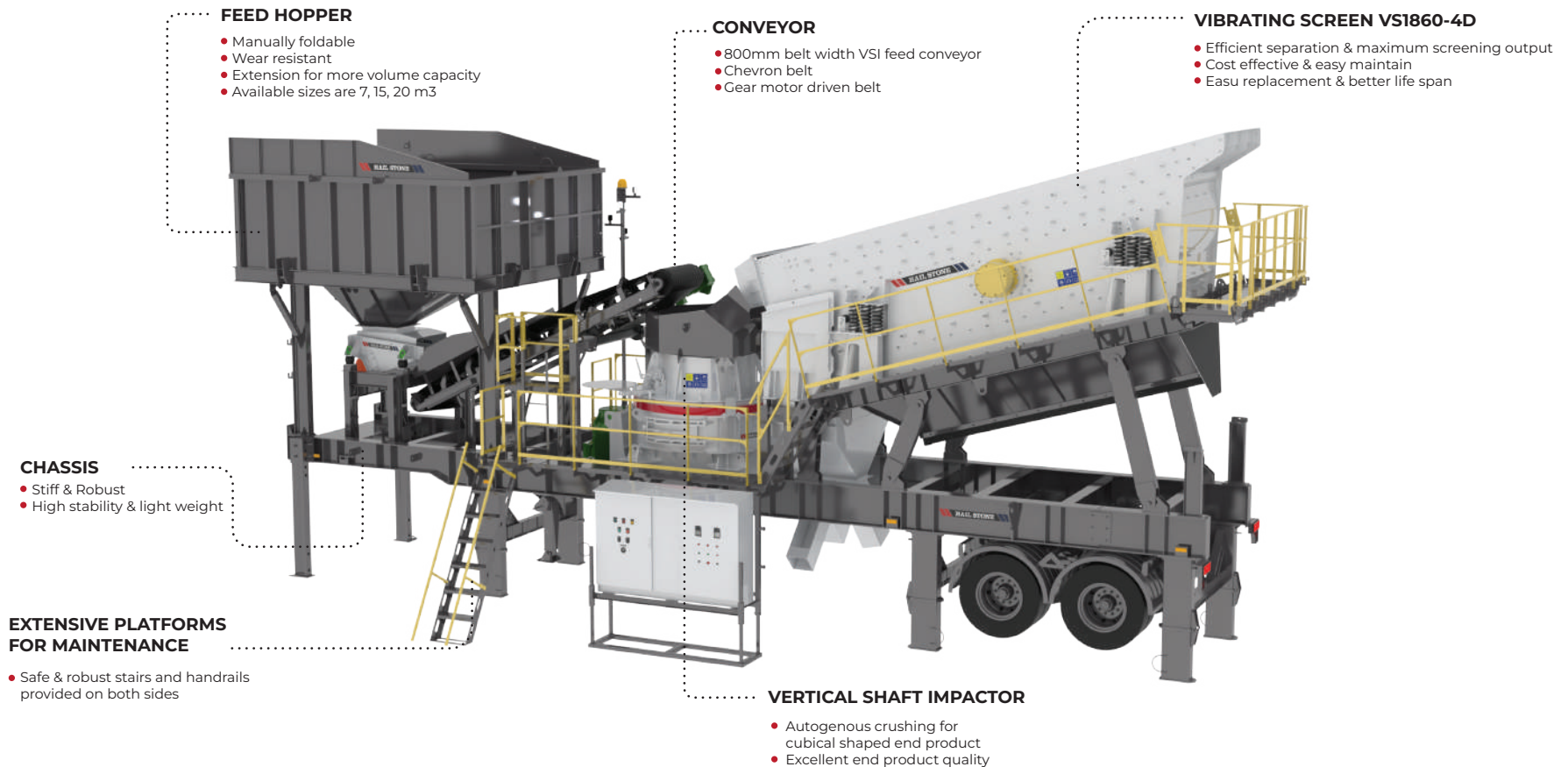

QUICK
INSTALLATION



EASY
TO MAINTAIN



DURABLE
DESIGN



LOW
OPERATION COST

Technical Specification

Model	SMART EP-7X187	SMART EP-8X225
Impactor		
Model	VSIEP7X187	VSIEP8X225
Power, kW (hp)	187 (250)	225 (300)
Number of drives	1	1
Dry weight, kg (lbs)	6930 (15278)	9325 (20558)
Max. Recommended feed size*, mm	37	45
Throughput capacity, mtph	120 - 220	150 - 350
Vibrating Screen		
Model	VS1850-4D	VS1860-4D
Deck Size, mm	5000 x 1850	5500 x 1850
No. of Decks	4	4
Feeder		
Model	PFVM12085	PFVM17580
Capacity, mtph	100 - 150	250 - 300
Motor Power, kW(hp)	1 X 2.2	2 X 1.5
Hopper		
Capacity, m ³	7/15/20*	7/15/20*
Feeding Height, mm	5700*	5700*
VSI Feed Conveyor		
Belt Width, mm	800	800
Length, m	5	5
Motor Power, kW(hp)	5.5	5.5
Dimensions		
Transportation (L x W x H), mm (in)	14945 x 3040 x 4650 (588 x 120 x 183)	16738 x 3070 x 4687 (659 x 121 x 184)
Working (L x W x H), mm (in)	14300 x 6530 x 5800 (562 x 257 x 228)	16118 x 4980 x 7096 (634 x 196 x 279)
Weight, kg (lbs)	34000 (74957)	39000 (86190)

*Feed height depends upon hopper capacity

WHEEL MOUNTED JAW CRUSHER

HW-JC Series

Portable plants are the most convenient option way to build even complex crushing and mineral processing sites. They are very easy to move from one site to the other. Hailstone wheel mounted primary crusher is equipped with jaw crusher and the basic arrangement uses a feeder with grizzly, provided with a large system destined to the wheel loader feeding. Robust construction for the toughest of hard rock crushing sites.

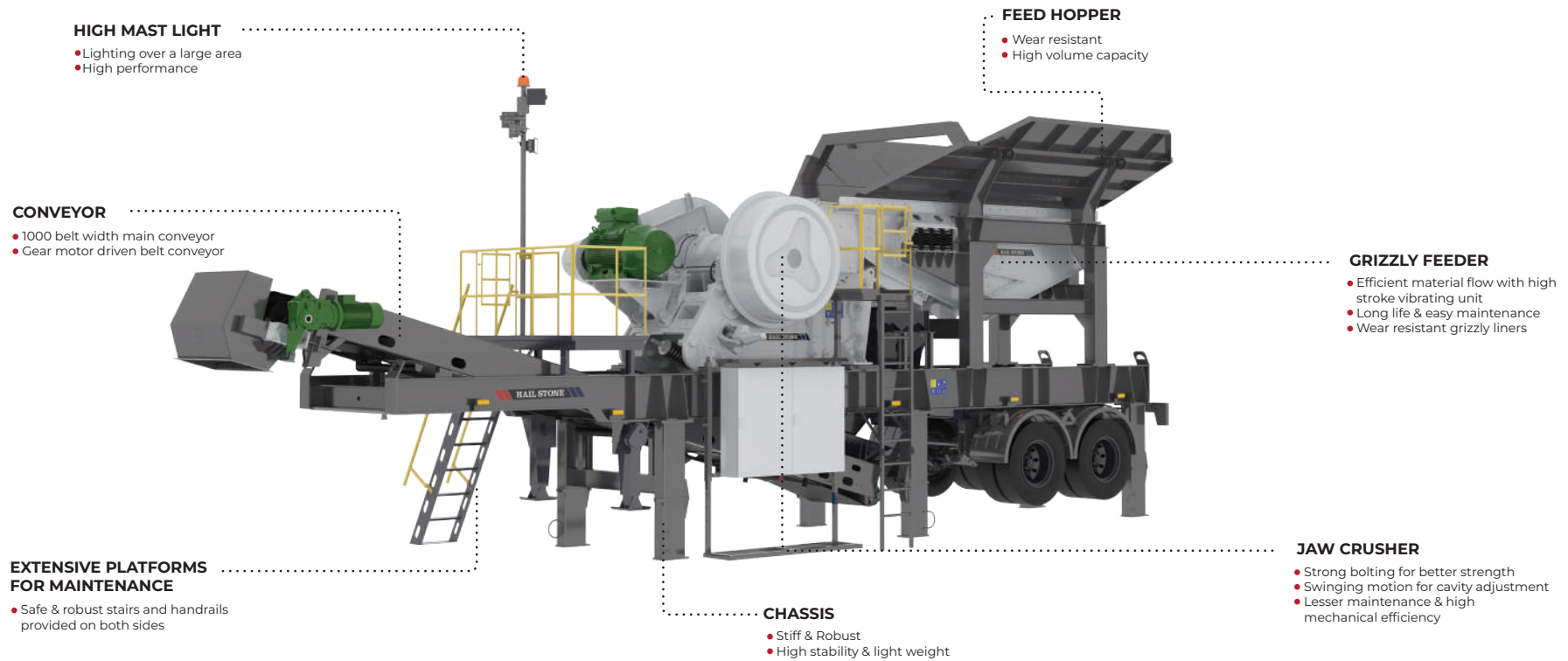

**STIFF &
ROBUST CHASSIS**



**SCALP
GRIZZLY**

Technical Specification

Model	HW130	HW145
CRUSHER		
Model	JC130	JC145
Opening size, mm (in)	1067 x 813 (42 x 32)	1143 x 876 (45 x 34.5)
C.S.S Range, mm	70 - 200	70-200
Capacity, tph	127 - 520	150-550
System		
Hopper capacity,m ³	10*	10*
Grizzly Feeder	GFEM4211	GFEM4211
Feeder size mm (in)	4200 x 1100 (165.3 x 43.3)	4200 x 1100 (165.3 x 43.3)
Main conveyor		
Belt width ,mm (in)	1000 (39.4)	1000 (39.4)
Discharge height, mm (in)	2088 (82.2)	2088 (82.2)
Fines conveyor (Optional)		
Belt width ,mm (in)	500 (19.7)	500 (19.7)
Discharge height, mm (in)	1700 (67)	1700 (67)
Drive power		
Total power, kW(hp)	135.6 (182)	157.6 (211.3)
Dimensions		
Transportation (L x W x H), mm (in)	13555 X 2993 X 4749 (533.7 x 117.8 x 187)	13555 X 2993 X 4749 (533.7 x 117.8 x 187)
Working (L x W x H), mm (in)	13384 x 4818 x 5422 (527 x 190 x 213.5)	13884 x 4818 x 5422 (547 x 190 x 213.5)
Weight, kg (lbs)	38000 (83980)	41000 (90400)

With optional Hydraulic landing leg

WHEEL MOUNTED CONE CRUSHER

HW-EC Series

Hailstone wheel mounted cone crusher is a perfect choice when there is a requirement of efficient secondary, tertiary and fine crushing with high productivity, good reduction ratio. According to the crushing requirement, two or three stages portable processes, one can find the right cone crushers from the EC and HF series.

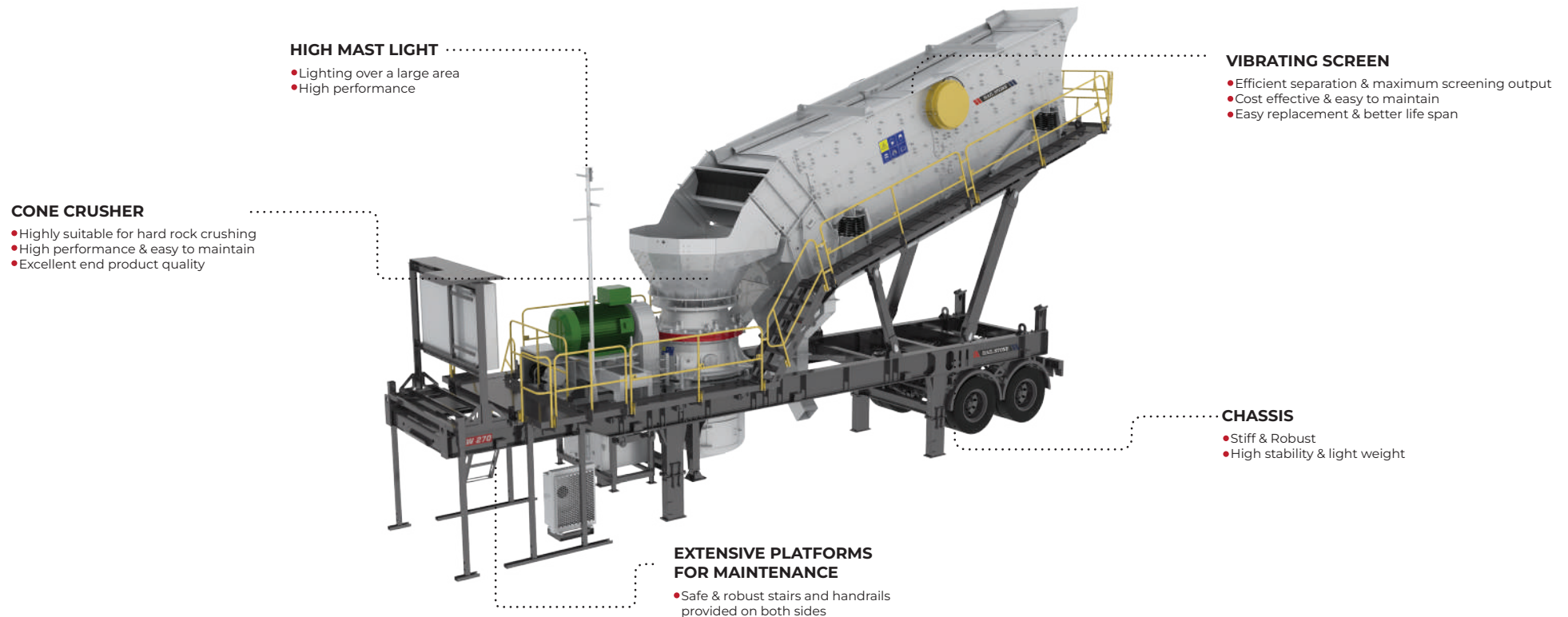

**HIGHER
CAPACITY**



**EXCELLENT
PRODUCT QUALITY**



**BUILT - IN
SAFETY FEATURES**



**EFFICIENT
AND RELIABLE**

Technical Specification

Model	HW270	HW250	HW350
CRUSHER			
Model	HF270	EC2500	EC3500
MAXMIUM FEED, mm (in)	137 (5 ^{25/64})	190 (7 ^{31/64})	200 (7 ^{56/64})
C.S.S Range, mm	8 - 40	10 - 38	19 - 45
Capacity, tph	70 - 280	127 - 490	200 - 440
Screen			
Model	DS1860-4D	DS1860-4D	VS600200-4D
Length, mm (in)	6000 (236.3)	6000 (236.3)	6000 (236.3)
Width, mm (in)	1800 (70.9)	1800 (70.9)	2000 (70.9)
Power, kW (hp)	15 (20)	15 (20)	22 (30)
Drive power			
Total power, kW (hp)	247 (331)	182.5 (245)	280 (375)
Dimensions			
Transportation (L x W x H), mm (in)	13680 x 3070 x 4620 (538.6 x 120.9 x 181.9)	14020 x 2710 x 4473 (552 x 106.4 x 176)	15500 x 3200 x 4475 (610.2 x 125.9 x 176.2)
Working (L x W x H), mm (in)	13190 x 5160 x 6842 (519.3 x 203.1 x 269.4)	13146 x 5282 x 7651 (517.6 x 208 x 301)	13671 x 5400 x 8420 (538.2 x 212.6 x 331.5)
Weight, kg (lbs)	40152 (88520)	48000 (106080)	56000 (123760)

With optional Hydraulic landing leg and screen lifting

WHEEL MOUNTED VSI

HW-EP Series

Hailstone wheel-mounted vertical shaft impactor is the most convenient solution for diverse crushing operations in construction, industrial minerals, metallic minerals and waste and recycling applications. Equipped with hailstone vertical shaft impactor is used in the third or fourth crushing stage in order to secure high cubicity of the end products meeting all IS, BS, NHA1 & MoRTH product standards.

HIGH MAST LIGHT

- Lighting over a large area
- High performance

VERTICAL SHAFT IMPACTOR

- Autogenous crushing for cubical shaped end product
- Excellent end product quality
- Max. feed Size 57 mm

VIBRATING SCREEN

- Efficient separation & maximum screening output
- Cost effective & easy to maintain
- Easy replacement & better life span

CHASSIS

- Stiff & Robust
- High stability & light weight

EXTENSIVE PLATFORMS FOR MAINTENANCE

- Safe & robust stairs and handrails provided on both sides



**HIGH VALUE
PROPOSITION**



**HIGHER
QUALITY**



**MINIMIZED
COST**



**HIGH
CLASSIFICATION**

Technical Specification

Model	HW8X
Crusher	
Model	EP8X
Feeding size, mm (in)	45 (1.8)
Capacity, tph	150 - 350
Screen	
Model	DS1860-4D
Length, mm (in)	6000 (236.3)
Width, mm (in)	1800 (70.9)
Power, kw (hp)	15 (20)
Drive power	
Total power, kW (hp)	240 (325)
Dimensions	
Transportation (L x W x H), mm (in)	14245 x 2995 x 4750 (560.8 x 117.9 x 187)
Working (L x W x H), mm (in)	13500 x 4815 x 8160 (531.5 x 189.6 x 321.3)
Weight, kg (lbs)	39000 (86190)

With optional Hydraulic landing leg and screen lifting

JAW CRUSHER

JC Series

Hailstone jaw crusher design and its material specifications offer a perfect crushing solution to the customer. High quality materials with superior finishing are used in Hailstone jaw crushers for better performance.

Our experience in crushing field and knowledge in metallurgy provides better assistance in bringing a foremost manufacturing grade for machine.



**NON-WELDED
DESIGN**



**BETTER
ANCHORING**



**EASY
OPERATION**



**FASTER
ROI**

Technical Specification

Model	JC45	JC100	JC130	JC145	JC180	JC220	JC270
Feed opening, mm x mm (in x in)	711 x 407 (28 x 16)	914 x 660 (36 x 26)	1067 x 813 (42 x 32)	1143 X 876 (45 x 34.5)	1194 x 945 (47 x 37.2)	1320 x 1080 (52 x 42.5)	1400 x 1220 (55x48)
CSS range, mm	20 - 100	60 - 175	70 - 200	70 - 225	70 - 225	100 - 250	125 - 250
Total weight, kg (lbs)	8000 (17680)	12200 (26896.4)	19690 (43409)	24300 (53572)	32900 (72532)	44200 (97444.4)	59440
Drive power, kW (hp)	37 (50)	75 (100)	110 (150)	132 (180)	160 (220)	160 (220)	200 (270)
Speed, rpm	360	330	260	260	230	220	220
Closed Side Setting, mm (In)	Capacity (MtpH)						
	JC45	JC100	JC130	JC145	JC180	JC220	JC270
20 (3/4)	15 - 22						
40(1 5/8)	20 - 30						
60 (2 3/8)	26 - 35	105 - 135	-	-	-	-	-
70 (2 3/4)	30 - 38	125 - 155	127 - 180	150 - 210	170 - 230	-	-
80 (3 1/8)	35 - 50	140 - 180	160 - 220	170 - 235	190 - 268	-	-
90 (3 1/2)	48 - 60	160 - 200	195 - 230	180 - 270	205 - 298	-	-
100 (4)	58 - 70	175 - 225	208 - 265	205 - 290	230 - 322	245 - 375	-
125 (5)		220 - 280	260 - 330	250 - 350	280 - 388	295 - 450	345-480
150 (6)		265 - 335	310 - 390	310 - 420	335 - 471	340 - 520	405-560
175 (7)		310 - 390	360 - 455	380 - 480	380 - 538	410 - 590	455-640
200 (8)		-	400 - 520	420 - 550	504 - 610	430 - 665	530-730
225 (9)		-	-	-	-	510 - 705	585-810
250 (10)		-	-	-	-	560 - 805	650-895

CONE CRUSHER

HF Series

The HF cone crusher heavy-duty design is based on two-point supported main shaft that allows high performance steep cavity designs. This strong design allows high crushing performance due to high power and crushing force levels utilized.

This stone regurgitating giant with small foot print is carefully engineered and created with unmatched performance assuring smooth running in any quarry or mining applications, takes less land to stand. Hydraulically adjustable CSS, automation, and freedom to select different crushing chamber with high performance features make the machine adaptable and user friendly.

Relatively lower CAPEX & OPEX makes HF series cone crusher the most customer friendly with quickest ROI.



EXCELLENT
VERSATILITY



SAFE
TO OPERATE



EASY
TO HANDLE

Technical Specification

Model	HF150	HF220	HF270
Drive power, kW (hp)	75 - 110 (100 - 150)	132 - 160 (180 - 220)	132 - 220 (175 - 300)
Total weight, kg (lbs)	10520 (23143)	13500 (29765)	15800 (34833)
Stroke options, mm (in)	25,30 (1, 1 ^{3/16})	18,22,28,36 (11/16, 7/8, 1 ^{7/64} , 1 ^{13/32})	18,25,28,32,36,40 (11/16, 1, 1 ^{7/64} , 1 ^{1/4} , 1 ^{3/32} , 1 ^{9/16})
Cavity	Feed opening		
Fine, mm (in)	-	-	90 (3 ^{35/64})
Medium fine, mm (in)	95 (3 ^{3/4})	90 (3 ^{35/64})	-
Coarse, mm (in)	180 (7 ^{1/16})	190 (7 ^{12/25})	220 (8 ^{11/16})
"Closed Side Setting mm (in)"	Capacity (MtpH)		
	HF150	HF220	HF270
8 (5/16)	-	-	70 - 90
10 (3/8)	58 - 95	70 - 90	80 - 130
15 (19/32)	65 - 123	77 - 99	105 - 175
20 (25/32)	84 - 135	100 - 110	120 - 230
25 (1)	105 - 147	126 - 165	150 - 265
30 (1 3/16)	132 - 160	144 - 205	165 - 280
35 (1 3/8)	-	162 - 250	-
40 (1 9/16)	-	175 - 260	-

CONE CRUSHER

EC Series

Hailstone EC series cone crushers are an excellent choice as secondary crushers in combination with a jaw or a primary gyratory crusher or in the third or fourth crushing stage. Thanks to their versatility, these crushers will enable you to cope with most production requirements in the changing future.

Operation cost is minimized by incorporating hydraulic chamber adjustments for easier operation & thereby resulting in faster ROI.

The crushing speed and throw were well designed for better inter-particle crushing action which yields better production and high quality shaped products.



HIGH
PERFORMANCE



MAXIMUM
AVAILABILITY



EXCELLENT
VERSATILITY



EASY
TO OPERATE

Technical Specification

Model	EC2500	EC3000	EC3500	EC4000	EC6000
Maximum feed opening, mm (in)	190 (7 ^{1/2})	225 (7 ^{7/8})	241 (9 ^{1/2})	255 (10)	351 (13 ^{7/8})
Total weight, kg (lbs)	17000 (37480)	21500 (47400)	24000 (52911)	26500 (58423)	41000 (90610)
Drive power, kW (hp)	160 (220)	225 (300)	250 (335)	315 (425)	450 (600)
Closed Side Setting, mm (In)	Capacity (MtpH)				
	EC2500	EC3000	EC3500	EC4000	EC6000
8 (5/16)	-	90 - 130	-	135 - 175	
10 (3/8)	99 - 143	105 - 150	127 - 154	155 - 210	175 - 220
13 (1/2)	132 - 176	130 - 185	165 - 204	195 - 265	230 - 290
16 (5/8)	149 - 204	155 - 230	198 - 242	235 - 315	280 - 350
19 (3/4)	165 - 215	180 - 250	220 - 264	260 - 345	320 - 400
22 (7/8)	176 - 231	190 - 260	242 - 286	285 - 375	345 - 430
25 (1)	187 - 253	210 - 290	253 - 308	300 - 400	365 - 455
32 (1 1/4)	204 - 264	220 - 310	275 - 352	310 - 440	405 - 535
38 (1 1/2)	220 - 286	240 - 350	330 - 418	360 - 500	445 - 605
45 (1 3/4)		280 - 400	385 - 484	400 - 555	510 - 700
50 (2)					580 - 790

ROLLER CRUSHER

HRP Series

Roller crusher uses a method of inter-particle comminution by drawing in a bed of material between two rotating rollers. The rotating rollers generate such a high pressure that it grinds the feed material to the smaller grain size. Hailstone roller crusher produces high quality sand meeting Indian and global specifications

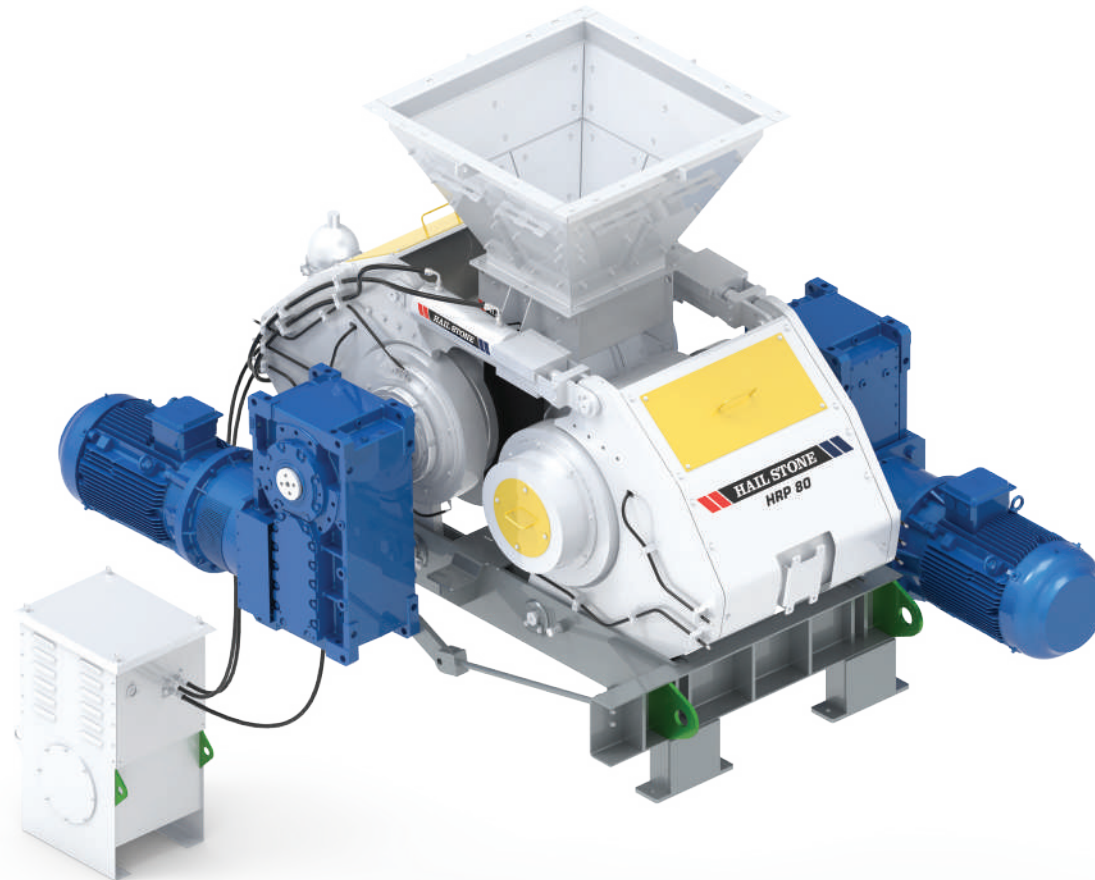

HIGH QUALITY
SAND



HIGHER
AVAILABILITY



LESS POWER
REQUIREMENT



SAFE AND EASY
TO OPERATE

Technical Specification

Model	HRP80
Maximum feed size, mm (in)	35 (1.4)
Drive power, kW (hp)	2 x 75 (2 x 100)
Capacity, mtpH	60 - 90
Crusher speed, rpm	19 - 38
Total weight, kg (lbs)	12000 (26520)

VERTICAL SHAFT IMPACTOR

EP Series

Hailstone Vertical Shaft Impactor improves the and shape of stone, reducing and easing the screening task while producing superior products at a minimum cost

Hailstone VSI which works on the principle of Rock on Rock collision has already proven, that it is the best sand making equipment among existing machines around the globe meeting majority of IS, BS, NHA1 & MoRTH product standards.



**MINIMIZED
COST**



**EXCELLENT
CRUSHABILITY**



**HIGH
QUALITY PRODUCTS**



**BENEFITS
OF CASCADE**

Technical Specification

Model	EP6X55	EP6X75	EP6X110	EP7X160	EP7X187	EP8X225	EP8XX320	EP8XX374	EP10XX450	EP10XX630
Power, kW (hp)	55 (75)	75 (100)	110 (150)	160 (220)	187 (250)	225 (300)	2 x 160 (2 x 220)	2 x 187 (2 x 250)	2 x 225 (2 x 300)	2 x 315 (2 x 425)
Number of drives	1	1	1	1	1	1	2	2	2	2
Dry weight, kg (lbs)	4500 (9921)	4800 (10582)	5200 (11464)	6880 (15167)	6930 (15278)	9325 (20558)	10840 (23898)	10950 (24141)	12655 (27899)	13275 (29266)
Max. Recommended feed size, mm (in)	32 (1.3)	32 (1.3)	37 (1.5)	35 (1.4)	35 (1.4)	45 (1.8)	45 (1.8)	45 (1.8)	60 (2.4)	60 (2.4)
Throughput capacity, mtph	40 - 80	45 - 100	60 - 160	100 - 210	120 - 220	150 - 350	210 - 420	240 - 520	310 - 560	400 - 750

HORIZONTAL SHAFT IMPACTOR

HS Series

Hailstone HSI crushers are designed to minimize maintenance and to deliver high performance in primary, secondary & tertiary crushing applications.

Maximum production and minimum downtime are the salient features of Hailstone HSI. Careful design of blow -bar, rotor and easy interchangeability of liners contributes for maximum production and less down time. Hydraulic apron assisted mechanical adjustments is easy to perform. Liners used are adaptable for sticky materials which makes the HSI different from other crushers by making it suitable for all rocks.

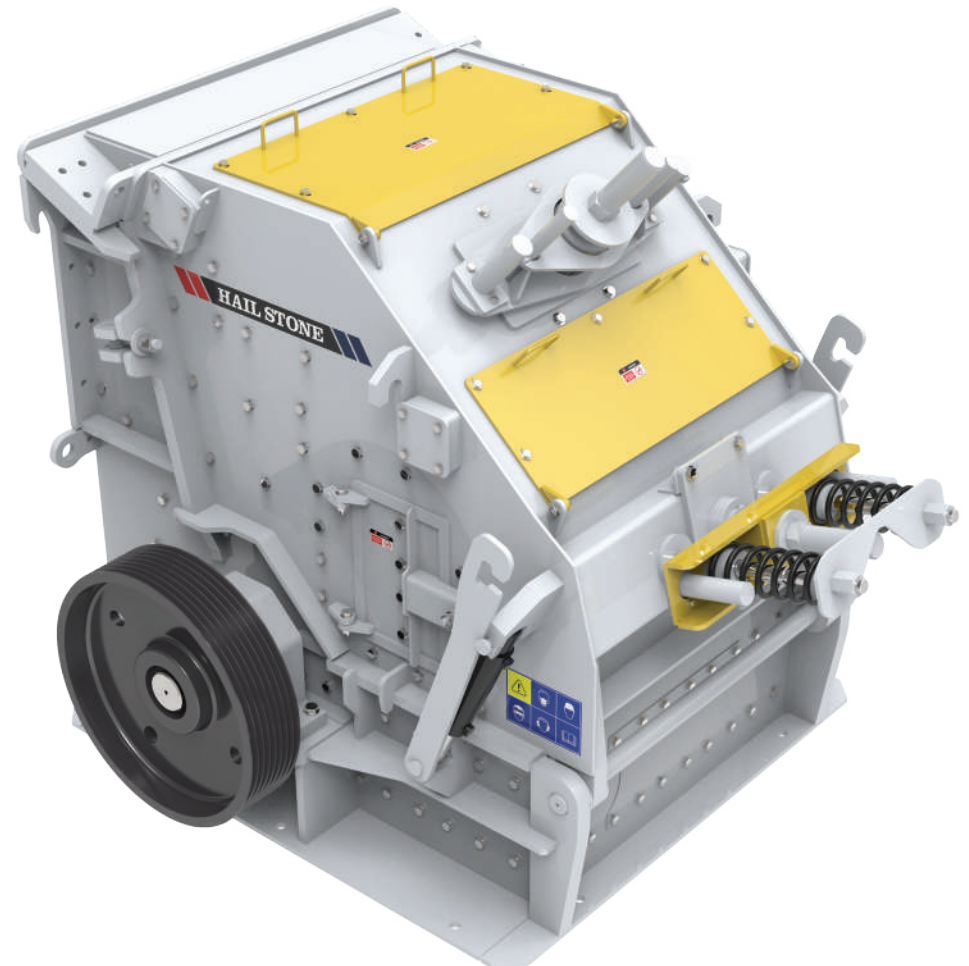

COMPACT
DESIGN



HIGHER
CAPACITY



EXCELLENT
REDUCTION RATIO

Technical Specification

Model	HSSI 1213	HSTI 1110
Power, kW (hp)	200 - 250 (250 - 350)	160 - 250 (220 - 340)
Capacity range, mtph	180 - 280	180 - 250
Dry weight, kg (lbs)	14000 (30865)	14750 (32518)
Maximum feed size, mm (in)	400 (15.7)	150 (5.9)
Feed opening (L x W), mm (in)	1320 x 879 (52 x 34.6)	1120 x 200 (44 x 7.8)
No. of blow bars	4	4
Application	Secondary/Tertiary	Tertiary

VIBRATING SCREEN

VS Series

Hailstone vibrating screens are circular-motion inclined screens in two, three and four deck designs. Standard inclination degrees are selected depending on the size of the machine. The decks can be equipped with any kind of modern screening media of polyurethane and rubber, wire mesh or steel plate depending upon the material.

Well positioned rotary shaft at its center of gravity gives the screen a motion that follows a circular profile at every point on the screen as it runs; result in excellent efficiency in all stages of crushing operations.

Hailstone vibrating screens have shown themselves to be extremely reliable, economic, easy to use and suitable for most of the screening applications.

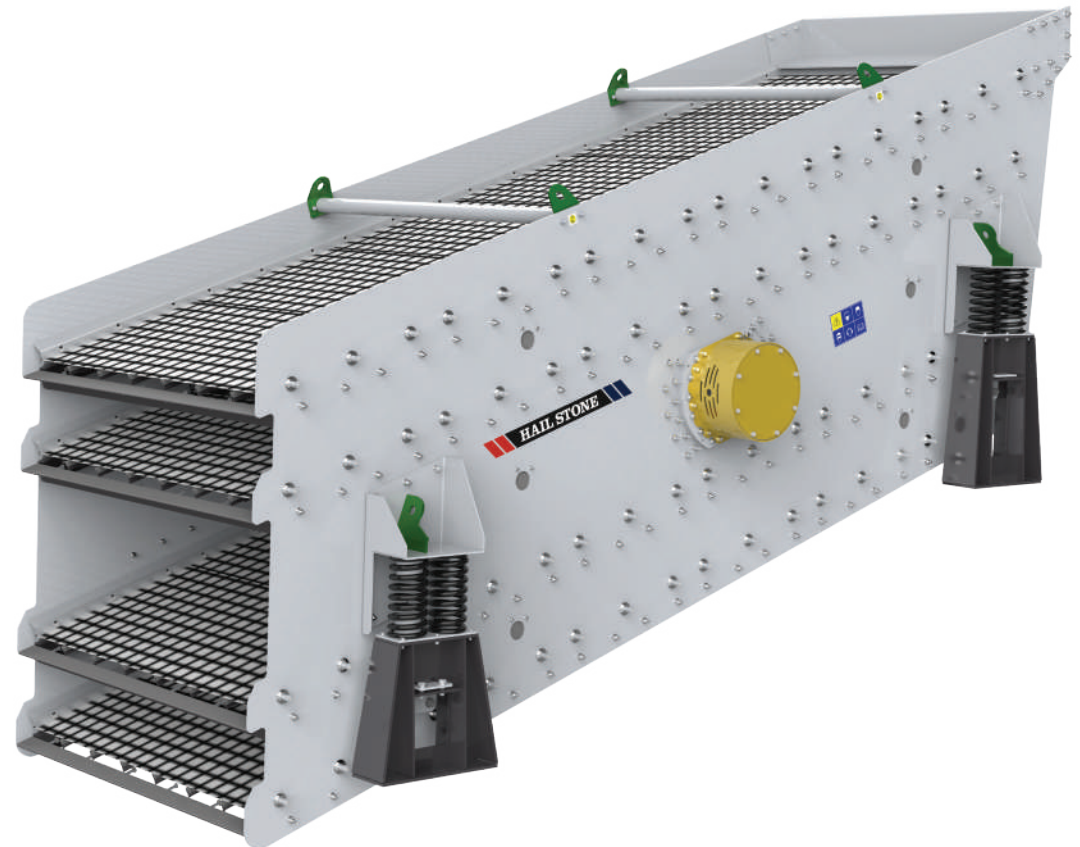

COMPACT
AND MODULAR DESIGN



COST
EFFECTIVE



EASY
TO MAINTAIN

Technical Specification

Model	Length mm	Width mm	Screening Area m2	Approximate Weight kg (lbs)	Number Of Decks	Drive Power kW (hp)
VS400150-2D	4000	1500	6	4051 (8931)	2	15 (20)
VS400150-3D				4560 (10053)	3	15 (20)
VS400150-4D				6294 (13876)	4	15 (20)
VS1845-2D	4500	1850	8.3	4400 (9700)	2	15 (20)
VS1845-3D				5220 (11508)	3	15 (20)
VS1845-4D				6240 (13757)	4	15 (20)
VS1855-3D	5500	1850	10.17	6350 (14000)	3	15 (20)
VS1855-4D				8050 (17791)	4	22 (30)
VS600200-2D	6000	2000	12	5161 (11378)	2	15 (20)
VS600200-3D				8015 (17670)	3	22 (30)
VS600200-4D				9320 (20547)	4	22 (30)
VS610260-3D	6100	2600	15.86	13000 (28660)	3	30 (40)
VS610260-4D				16000 (35274)	4	30 (40)
DS1860-4D	6000	1850	11.1	8500 (18785)	4	15 (20)

BUCKET WHEEL CLASSIFIER

BCD & DUO Series

Highly comprehensive range of dewatering options for fine materials covering numerous applications and sectors.

The washing equipment designed to operate with maximum versatility and can support different requirements such as maximum retention of fines or maximum disposal of fines meeting all IS, BS, NHA1 & MoRTH product standards.



SUPREME
ENGINEERING



ECONOMICAL



COMPACT
DESIGN



EASY
TO MAINTAIN

Technical Specification

Model	BCD1209	BCD1412	BCD1815	DUO80	DUO120	DUO160
Drive power, kW (hp)	5.5 (7.5)	7.5 (10)	15 (20)	5.5 (7.5)	7.5 (10)	7.5 (10)
Rotation speed, rpm	3.29	3.29	3.32	3.29	3.29	3.29
Unbalanced motor power, kW	2 x 1.5	2 x 1.5	2 x 3.8	2 x 1.5	2 x 2.2	2 x 1.5 (DWS) 2 x 3.8 (RS)
Number of products	1	1	1	2	2	2
Capacity, mtph	45 - 60	60 - 80	90 - 120	40 - 80	70 - 90	100 - 130
Maximum feed size, mm	< 8	< 8	< 8	< 8	< 8	< 8
Approximate weight, kg (lbs)	7622 (16804)	8522 (18788)	12032 (26526)	6400 (14144)	8630 (19026)	13164 (29022)
Dewatering screen size (L x W), mm (in)	2100 x 900 (83 x 35)	2100 x 1200 (83 x 47)	2450 x 1500 (96 x 59)	2117 x 1270 (83 x 50)	2480 x 1446 (98 x 57)	2100 x 1200 (DWS) (83 x 47)
Rinser screen size (L x W), mm (in)	-	-	-	-	-	2800 x 1300 (110 x 51)

ADDWASH

AW Series

ADDWASH is an improvised fine-material washing solution, as an out-turn of long and engrossed research and development by our devoted engineers. Its unrivaled performance, low running cost and minimum power consumption makes the machine a pet amid its owners.

Our unique vibro-motor and auxiliary system distributes material flow evenly over the entire screening area and make sure, that maximum energy transferred to the material with exceptional dewatering efficiency.

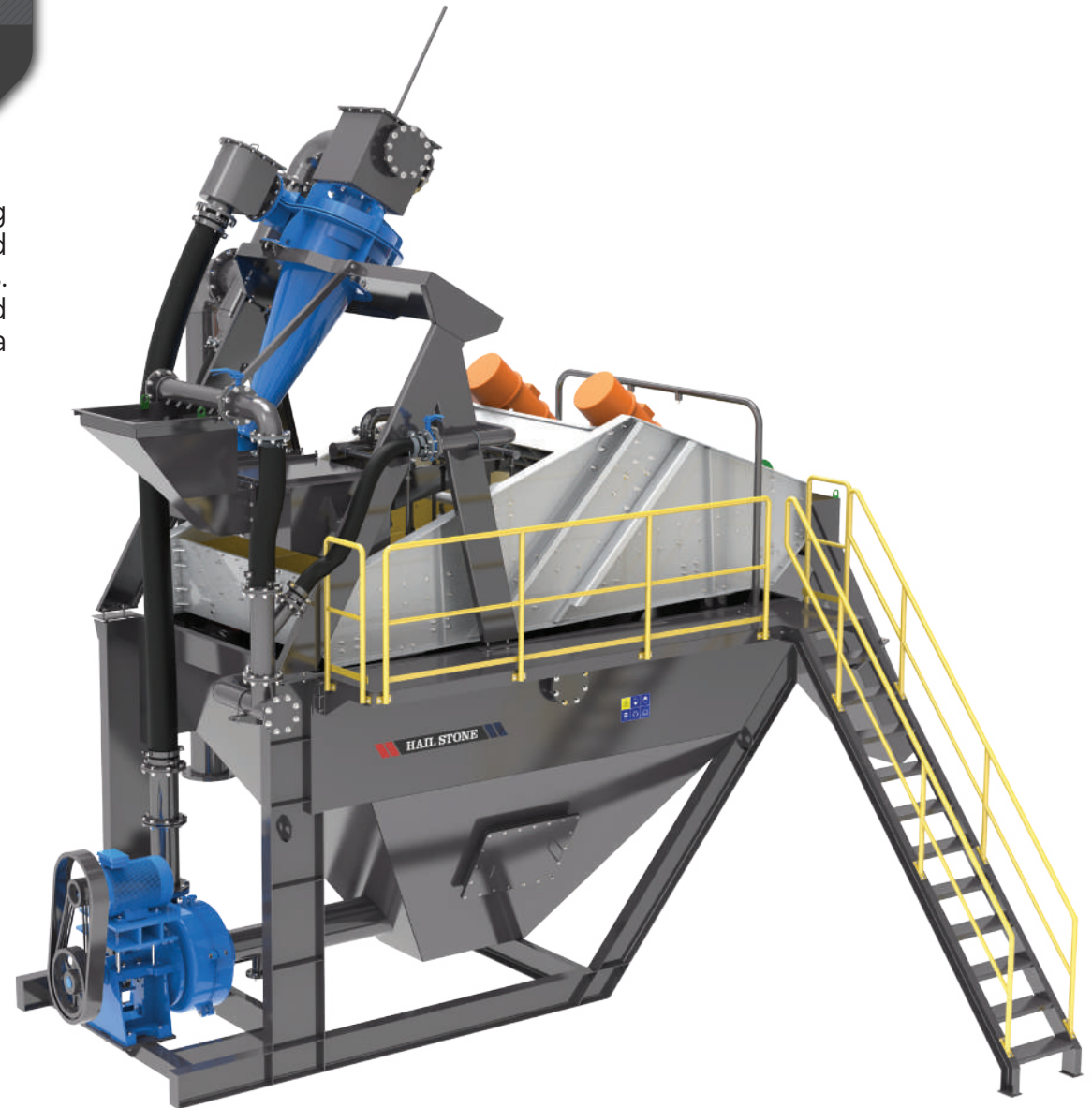

MODULAR
TECHNOLOGY



CYCLONE
DESIGN



LOWER
OPEX

Technical Specification

Model		ADDWASH85	ADDWASH125	ADDWASH205	ADDWASH250	ADDWASH280	ADDWASH305
Total power,kW (hp)		22.6	26.1	45	62.2	75	75
Water required, m ³ /hr		150	180	250	350	350	350
Capacity, mtph		50 - 70	70 - 105	100 - 150	150 - 200	170 - 180	250 - 300
Dewatering screen	Screening Size(L x W), mm (in)	2400 x 1200 (96 x 48)	2400 x 1800 (96 x 72)	4000 x 2100 (160 x 84)	3200 x 1500 (126 x 59.1)	4000 x 2100 (160 x 84)	4000 x 2100 (160 x 84)
	Motor Power, kW (hp)	2 x 3.8	2 x 3.8	2 x 7.5	2 x 7.5	2 x 7.5	3 x 7.5
Rinser screen	Screening Size(L x W),mm (in)	-	-	-	4000 x 1500 (160 x 59.1)	4000 x 2100 (160 x 84)	4800 x 2100 (192 x 84)
	Motor Power, kW (hp)	-	-	-	2 x 4.3	2 x 7.5	3 x 7.5
Slurry pump size	Suction, in	4	6	8	8	8	8
	Discharge, in	3	4	6	6	6	6

CLARIFIER

CF Series

The Hailstone Clarifier operates by the principles of gravity and particle interactions, with solid settling downwards and liquids rising to the top as they separate. Hailstone Clarifier focuses on maximising the settling of solids in the underflow, and minimising any escape of solids in the overflow stream to provide cleaner water for immediate reuse in the system.

Hailstone Clarifier is designed for seamless integration with our washing equipments. Clarifier uses the latest sand washing technology, that recycles up to 90% of processed water and makes it available for re-use in the system.



EASY
TO INSTALL



HYDRAULIC
FLOCCULANT SYSTEM



ROBUST
RAKE SYSTEM



BEST LONG -TERM
PERFORMANCE

Technical Specification

Model	CF120	CF200	CF250	CF300
Maximum feed rate (m ³ /hr)	200	400	600	900
Sludge flow rate, mtph	10	20	30	45
Sludge pump power, kW(hp)	15 (20)	22 (30)	22 (30)	22 (30)
Rake power requirement, kw(hp)	3.3 (4.5)	3.3 (4.5)	3.3	3.7 (5)
Tank diameter, m	6	8	10	12
Flocculant station power, kw (hp)	3 (4)	3 (4)	3	3 (4)
Total power kw (hp)	21.5 (29)	29.05 (39)	30 (40)	30 (40)

AIR CLASSIFIER

AC Series

Dynamic classifiers, in which the rotary type is the dominating solution for the aggregate industry. The main advantage with the dynamic rotor type classifiers is that it has no need for a separate fan and filter assembly. This lowers the investment cost and reduces the machine assembly footprint and makes the system easier to transport in a mobile configuration.



EASY
MANEUVERABILITY



HIGHER
AVAILABILITY

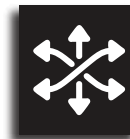

EXCELLENT
VERSATILITY



HIGH
CLASSIFICATION

Technical Specification

Model	AC50	AC100	AC200
Feed Height, mm	6000	7000	8200
Diameter, mm	2400	3000	4500
Power, kW (hp)	22 (30)	30 (40)	55 (75)
Capacity, mtpH	40 - 50	80 - 100	150 - 200
Approximate weight, kg (lbs)	14193 (31366)	-	20902 (46193)
Feed size, mm	< 6	< 6	< 6

FEEDER

Pan Feeder

Hailstone feeders are designed for mobile, portable and stationary use as well as surface and underground operations for abrasive or soft rock, gravel, slag or other recycling and industrial materials. These Hardox plated Feeders are compatible with wide range of crushing equipment.



LONG LASTING
WEAR PARTS



FLEXIBLE & RELIABLE
IN OPERATION



EASY
INSTALLATION



MINIMUM
DOWNTIME

Technical Specification

Model	PFVM17580	PFVM2208	PFVM2210	PFVM2012
Effective length, mm	1750	2200	2200	2000
Effective width, mm	800	800	1000	1250
Power, kW(hp)	2 x 1.5	2 x 2.29	2 x 3.8	2 x 3.8
Capacity, mtph	250 - 300	300 - 350	400 - 450	500 - 550
Approximate weight, kg (lbs)	1100 (2431)	1300 (2873)	1479 (3261)	1729 (3812)
Top size of feed, mm	300	300	300	300

FEEDER

Grizzly Feeder

Hailstone feeders are designed for mobile, portable and stationary use as well as urface and under-ground operations for abrasive or soft rock, gravel, slag or other recycling and industrial materials. These feeders are compatible with wide range of crushing equipment.



LONG LASTING
WEAR PARTS



FLEXIBLE & RELIABLE
IN OPERATION



EASY
INSTALLATION



MINIMUM
DOWNTIME

Technical Specification

Model	GFEM2107	GFEM3209	GFEM4211	GFEM4513	GFEM4812	GF6113
Effective length, mm	2100	3200	4200	4500	4800	6100
Effective width, mm	700	900	1100	1300	1200	1300
Power, kW(hp)	2 x 1.5	2 x 3.8	2 x 5.5	2 x 7.5	2 x 6.1	1 x 30
Capacity, mtpH	50 - 100	250 - 300	350 - 400	500 - 550	500 - 600	550 - 600
Approximate weight, kg (lbs)	950 (2100)	2750 (6063)	4250 (9370)	6278 (13840)	4200 (9282)	8000 (17635)
Top size of feed, mm	350	500	700	1100	1100	1200

PLANT INSTALLATIONS



200 TPH - 3 STAGE C&S PLANT WITH WASHING SYSTEM



250 TPH - 3 STAGE C&S PLANT WITH WASHING SYSTEM

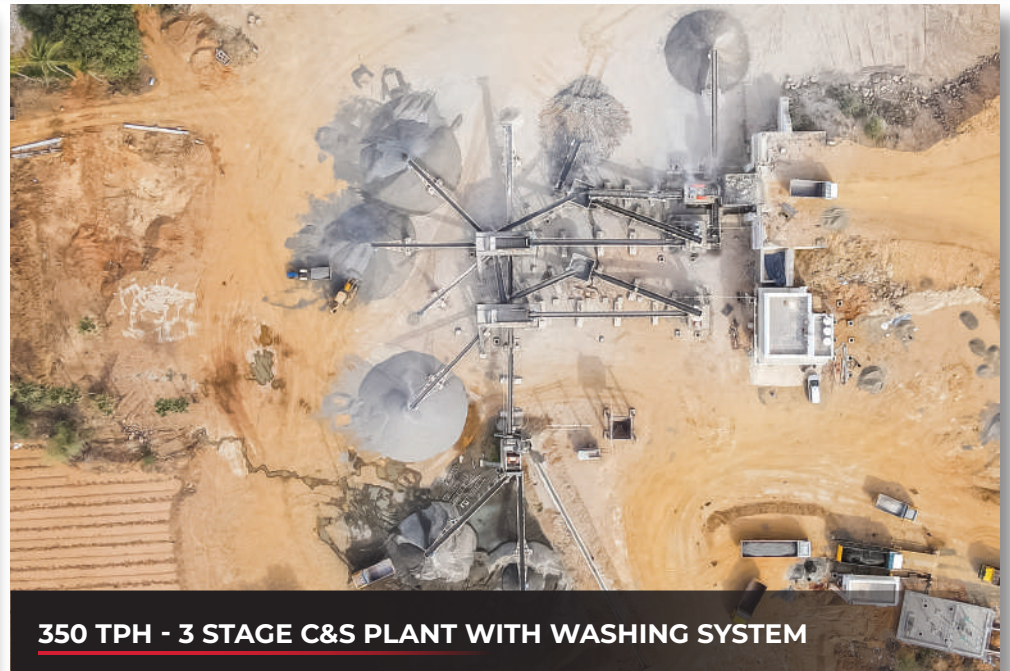

350 TPH - 3 STAGE C&S PLANT WITH WASHING SYSTEM



350 TPH - 3 STAGE C&S PLANT WITH WASHING SYSTEM



WHEEL MOUNTED 200 TPH - 2 STAGE C&S PLANT



SMART 200 TPH - 2 STAGE C&S PLANT



TRACK MOUNTED JAW CRUSHER

HAILSTONE

BUILT TO LEAD

CRUSHING | MINING | SCREENING | WASHING | RECYCLING SOLUTIONS



2500+
CUSTOMERS &
INSTALLATIONS

120+
PRODUCT
MODELS

ISO
9001 : 2015
CERTIFIED COMPANY

CE
CERTIFIED



HAILSTONE INNOVATIONS PRIVATE LIMITED

KINFRA Integrated Industrial Park, Kanjikode – 678 621, Kerala, India.

Mobile: +91 9746644588, | +91 8714634599 | E-mail: salesist@hailstoneinc.com

www.hailstonein.com

 @hailstoneinnovations



Scan here to reach our website